

2023  
**Outback**



The Subaru Outback. **Go where love takes you.**





## Inspiring out-of-office memos since '95.

Meet the redesigned 2023 Subaru Outback.

The first Outback wasn't just a way to get out there, but a reason to see something new—to have an adventure. That was 1995, and still the Outback continues to push ahead. From its advanced technologies and safety systems to its capable engineering, this SUV lets you know the outdoors is waiting. So take a personal day—or two.



Outback Limited in Brilliant Bronze Metallic with optional equipment.

<sup>1</sup> EPA-estimated fuel economy for 2023 Outback 2.5L trim levels at 32 highway mpg. Actual mileage may vary. <sup>2</sup> Comparison based on competitor information from manufacturer websites for non-hybrid 2022 model-year vehicles within the IHS Markit Non-Luxury CUV segment and current at time of printing. <sup>3</sup> Availability varies by trim level. See your retailer for details. <sup>4</sup> Based on Experian Automotive vehicles in operation vs. total new registrations for MY2012–2021 as of December 2021. <sup>5</sup> EyeSight is a driver assist technology, which may not operate optimally under all driving conditions. The driver is always responsible for safe and attentive driving. System effectiveness depends on many factors such as vehicle maintenance, weather and road conditions. See your Owner's Manual for complete details on system operations and limitations. <sup>6</sup> Automatic Emergency Steering requires Blind-Spot Detection. Not available on base Outback trim level. Optional on Premium trim level. See your retailer for details. <sup>7</sup> The DriverFocus Distraction Mitigation System is a driver recognition technology designed to alert drivers if their attention to the road wavers or if the driver's face appears to turn away. The driver is always responsible for safe and attentive driving. System effectiveness may be affected by articles of clothing worn on the head or face. See your Owner's Manual for complete details on system operation and limitations. <sup>8</sup> Requires Keyless Access with Push-Button Start and subscription to STARLINK Safety and Security Plus services. 6-month free trial included. Not available in all states. See your retailer for details.

### Most Adventurous

With standard Subaru Symmetrical All-Wheel Drive, 8.7 inches of ground clearance and a direct-injection SUBARU BOXER® engine, the 2023 Outback is designed for peace of mind on long drives, achieving up to 32 MPG<sup>1</sup>—better AWD fuel economy than the Honda Passport, Ford Edge and Jeep Grand Cherokee.<sup>2</sup> For next-level capability, you can opt for a turbocharged engine<sup>3</sup>—or get it standard with the Outback Wilderness, which features 9.5 inches of ground clearance.

### Most Reliable

Built on the strength of the Subaru Global Platform, the Outback has had years of experience on all types of terrain. Its record speaks for itself—97% of Subaru Outback vehicles sold in the last 10 years are still on the road today.<sup>4</sup>

### Safest

The 2023 Outback takes an active role in helping you stay safe, thanks to innovations such as standard Subaru EyeSight® Driver Assist Technology,<sup>5</sup> which has been updated to expand its field of view and includes Advanced Adaptive Cruise Control with lane centering and new Automatic Emergency Steering.<sup>3,6</sup> There's also the DriverFocus® Distraction Mitigation System to help reduce distracted or drowsy driving.<sup>3,7</sup>

### Most Advanced

More options means more ease. An updated 11.6-inch touchscreen<sup>3</sup> makes it even easier to find what you need, while SUBARU STARLINK® Multimedia lets you connect just about anywhere through standard Apple CarPlay® and Android Auto™ integration with available wireless connectivity.<sup>3</sup> Technologies such as Remote Engine Start with Climate Control help make the Outback a place of comfort.<sup>3,8</sup>



## Farther doesn't have to feel longer.

To keep distances engaging, the Outback delivers far-reaching connectivity. With its updated 11.6-inch touchscreen interface,<sup>1</sup> you have simple, easy access to SUBARU STARLINK Multimedia, now with available wireless connectivity<sup>1</sup> for Apple CarPlay® and Android Auto™ integration. For passengers, built-in Wi-Fi capability<sup>1,2</sup> offers a wide range of entertainment possibilities. Once everyone votes on what music to play, the Harman Kardon® premium audio system will bring that song to life through 12 speakers and a 576-watt-equivalent amplifier.<sup>1</sup>

Outback Touring with Java Brown Nappa Leather.



SUBARU STARLINK 11.6-inch Multimedia Navigation System<sup>1</sup>



Heated rear seats and USB-A and USB-C charge ports<sup>1</sup>



Harman Kardon® premium audio system<sup>1</sup>

## Welcoming you, personally.

From the moment you sit behind the wheel, available DriverFocus recognizes you and automatically adjusts the Outback to your preferences.<sup>1</sup> This includes driver seat settings, climate controls, exterior mirrors and even your choices for which vehicle system information appears on the screen.

<sup>1</sup> Availability varies by trim level. See your retailer for details. <sup>2</sup> Activation and subscription required. Internet access is purchased separately through AT&T with monthly, per gigabyte, and unlimited data options available. Existing AT&T customers have the option to add a line to their AT&T Mobile Share plan. See your retailer for details.

## Find a place that makes you forget to take a selfie.

The Outback is engineered to help you discover what's out there. When pavement is scarce, you can count on standard Subaru Symmetrical All-Wheel Drive, X-MODE® with Hill Descent Control and ample ground clearance. For packing up with ease, there are roof rails with integrated retractable roof crossbars.<sup>1</sup> Plus, the Outback has a towing capacity of up to 3,500 pounds,<sup>2</sup> meaning you can bring all your must-haves—and fun-to-haves, too.



Outback Wilderness in Geyser Blue with optional equipment.



Roof rails with increased load capacity and Anodized Copper-finish accents



9.5 inches of ground clearance



17-inch matte black alloy wheels with all-terrain tires



Functional off-road exterior upgrades

### The Outback Wilderness

Your itinerary becomes anywhere in the Outback Wilderness—an Outback that's heightened, quite literally, with 9.5 inches of ground clearance. Rugged cladding and Anodized Copper-finish accents reveal its bold nature, while its capable engineering drives the point home. For more fun while taking on the terrain, the Outback Wilderness is equipped with a further advanced dual-function X-MODE system, designed to work at higher speeds. This is combined with off-road-optimized gearing as well as increased approach, departure and breakover angles for tackling a greater variety of surfaces. The Outback Wilderness also has ladder-type roof rails for increased roof load capacity and comes with additional tow points for greater confidence when heading out.

<sup>1</sup> Availability varies by trim level. See your retailer for details. <sup>2</sup> Outback XT trim levels only. Trailer brakes may be needed. Some safety features, including X-MODE, Blind-Spot Detection and Rear Cross-Traffic Alert, may not function properly when towing. See your retailer for details.



## An extra set of eyes every time you drive.

Every Outback includes standard Subaru EyeSight Driver Assist Technology,<sup>1</sup> now with available Automatic Emergency Steering.<sup>2</sup> Equipped with a comprehensive suite of innovative safety features, EyeSight looks ahead, alerts you to potential dangers and can even intervene to help you avoid a collision.

EyeSight reduces the rate of rear-end crashes with injuries by up to **85%**<sup>3</sup>

Outback Touring in Cosmic Blue Pearl.



### Pre-Collision Braking

Can help slow and bring your Outback to a full stop if necessary.



### Lane Departure and Sway Warning

Can alert you if you drift to the edge of your lane and begin to cross into another.



### Advanced Adaptive Cruise Control with Lane Centering

Automatically helps keep you centered in your lane, at a safe distance behind the car in front of you—even in traffic and around curves.



### Pre-Collision Throttle Management

Can reduce engine power to help give you more time to react and to help minimize possible impact force in case of a collision.

1 EyeSight is a driver assist technology, which may not operate optimally under all driving conditions. The driver is always responsible for safe and attentive driving. System effectiveness depends on many factors such as vehicle maintenance, weather and road conditions. See your Owner's Manual for complete details on system operations and limitations. 2 Automatic Emergency Steering requires Blind-Spot Detection. Availability varies by trim level. See your retailer for details. 3 Based on data from 2013–2015MY Subaru models equipped with EyeSight through 2014. From an Insurance Institute of Highway Safety report published January 2016.

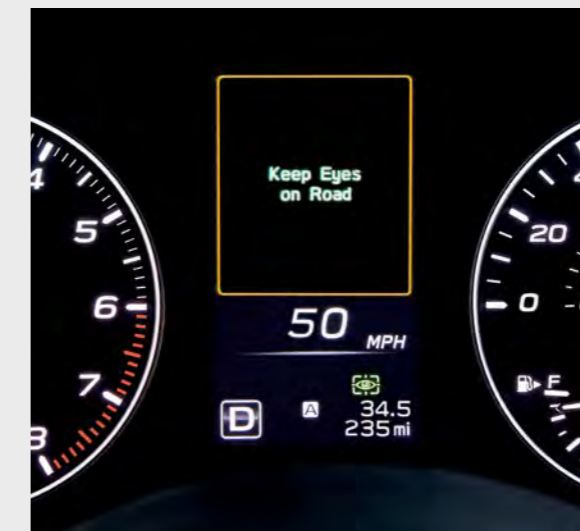

### DriverFocus<sup>®</sup> Distraction Mitigation System

Every day in the U.S., more than 1,000 people are injured in crashes reported to have involved a distracted driver.<sup>1</sup> As an industry leader in safety, Subaru developed the DriverFocus Distraction Mitigation System,<sup>2,3</sup> one of the first technologies of its kind. Engineered for both new and experienced drivers, it works together with Subaru EyeSight to help detect distracted or drowsy driving. If the driver's attention strays from the road for too long, DriverFocus can deliver visual and auditory alerts to bring attention back to the road.

1 Centers for Disease Control and Prevention, citing National Center for Statistics and Analysis. Distracted Driving: 2015, in Traffic Safety Research Notes. DOT HS 812 381. March 2017, National Highway Traffic Safety Administration: Washington, D.C. 2 The DriverFocus Distraction Mitigation System is a driver recognition technology designed to alert drivers if their attention to the road wavers or if the driver's face appears to turn away. The driver is always responsible for safe and attentive driving. System effectiveness may be affected by articles of clothing worn on the head or face. See your Owner's Manual for complete details on system operation and limitations. 3 Availability varies by trim level. See your retailer for details.

## Detect, alert, protect.

### Advanced Safety Features

The Outback represents the very latest in Subaru safety, down to the strong core of its Subaru Global Platform. For better visibility, there are standard LED Steering Responsive Headlights with High Beam Assist and an available 180-Degree Front View Monitor.<sup>1</sup> Thanks to a wide range of active safety technologies, peace of mind is possible just about anywhere.

Outback Onyx Edition XT in Cosmic Blue Pearl with optional and accessory equipment.



### Blind-Spot Detection

Using radar sensors, Blind-Spot Detection<sup>1,2</sup> warns you with a visual indicator on your exterior mirror if the system detects a vehicle in your blind spot. Another feature of this system, Lane Change Assist, alerts you with a flashing indicator on your exterior mirror if it senses a vehicle approaching at a higher speed in a neighboring lane and you signal for a lane change.



### Rear Cross-Traffic Alert

Rear Cross-Traffic Alert<sup>1,2</sup> uses radar sensors to help warn you of traffic approaching from the exterior as you are backing up, utilizing a flashing visual indicator on your exterior mirror and Rear-Vision Camera display as well as an audible warning.



### Reverse Automatic Braking

Reverse Automatic Braking<sup>1,3</sup> can detect objects directly behind your vehicle when backing up at a low speed and can help bring the Outback to a stop should an object be detected within its range and the brakes have yet to be applied. There's also the Rear-Vision Camera to help you keep an eye out.



### SUBARU STARLINK Safety and Security

The Outback features the latest STARLINK<sup>®</sup> Safety and Security<sup>1,4</sup> system, which can alert a first responder in an emergency, help police locate your vehicle if it's stolen and more. To get you started, new Outback drivers enjoy a free three-year STARLINK Safety Plus trial, which includes Advanced Automatic Collision Notification, Enhanced Roadside Assistance, SOS Emergency Assistance and more.

<sup>1</sup> Availability varies by trim level. See your retailer for details. <sup>2</sup> Blind-Spot Detection, Lane Change Assist and Rear Cross-Traffic Alert are systems designed to assist the driver by monitoring the rear and side areas of the vehicle during a lane change or reversing and are not a substitute for safe and attentive driving. <sup>3</sup> The Reverse Automatic Braking System is not a substitute for safe and attentive driving. System effectiveness depends on many factors, such as vehicle maintenance, weather and road conditions. Always exercise caution and use vehicle mirrors and the Rear-Vision Camera when backing up. See your Owner's Manual for complete details on system operation and limitations. <sup>4</sup> Activation with subscription required. Includes a 3-year trial subscription to Safety Plus services and a 6-month trial subscription to Safety and Security Plus services. The Concierge plan can be purchased annually or monthly. A credit card on file will be required for specific packages and for renewal purposes. Not available in all states. See your retailer for details.



Rest stops aren't the only chances to stretch.

1 Without available power moonroof. See your retailer for details. 2 Comparison based on competitor information from manufacturer websites for 2022 model-year vehicles within the IHS Markit Non-Luxury CUV segment and current at time of printing. 3 Availability varies by trim level. See your retailer for details. 4 Requires Keyless Access with Push-Button Start and subscription to STARLINK Safety and Security Plus services. 6-month free trial included. Not available in all states. See your retailer for details. 5 Touring trim level only. See your retailer for details.

Outback Limited with Warm Ivory Leather and optional equipment.

11 | 2023 Outback

### Expanding Possibility

Space goes a long way in the Outback, and with up to 109.0 cubic feet of passenger volume,<sup>1</sup> it's roomier than the Kia Sorento, Honda CR-V and Toyota RAV4.<sup>2</sup> A vast cargo area offers versatility with conveniences including a Hands-Free Power Rear Gate,<sup>3</sup> a 60/40-split folding rear seatback and new LED cargo and rear gate lights.<sup>3</sup> When it comes to comfort, you can set the perfect temperature even before you step in, thanks to Remote Engine Start with Climate Control.<sup>3,4</sup> Once inside, you're welcomed by genuine Nappa leather<sup>5</sup> and a new 12-way power driver seat.<sup>3</sup> There's also an 8-way power front-passenger seat,<sup>3</sup> along with heated<sup>3</sup> and ventilated front seats,<sup>5</sup> heated rear seats<sup>3</sup> and even a heated steering wheel.<sup>3</sup> When the moment calls for calm, you'll have as much as you need—this is the quietest Outback interior yet.

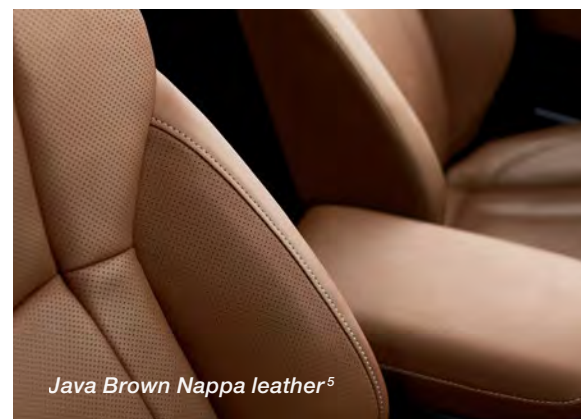

Java Brown Nappa leather<sup>5</sup>



Two-position memory driver seat and exterior mirrors<sup>3</sup>



Rear-seat comfort

## 2023 Outback | Trim Levels



### Outback

- 182-hp 2.5-liter 4-cylinder SUBARU BOXER engine with direct injection
- EyeSight Driver Assist Technology<sup>1</sup>
- Subaru Symmetrical All-Wheel Drive with Active Torque Vectoring
- Lineartronic<sup>®</sup> CVT (Continuously Variable Transmission) with 8-speed manual-mode paddle shifters
- X-MODE featuring Hill Descent Control
- Auto-on/off LED Steering Responsive Headlights with High Beam Assist
- LED fog lights
- 17-inch aluminum-alloy wheels
- Roof rails with integrated retractable crossbars and 4 tie-down points
- Cloth upholstery
- 6-way manually adjustable driver seat and 4-way manually adjustable front-passenger seat
- SUBARU STARLINK Dual 7.0-inch Multimedia with Apple CarPlay<sup>®</sup> and Android Auto<sup>™</sup> integration, SiriusXM<sup>®2</sup> including 4-month Platinum Plan and SiriusXM Travel Link<sup>®2</sup> trial, USB-A input port, 4 speakers, AM/FM stereo, Bluetooth<sup>®</sup> audio streaming, hands-free phone and text messaging connectivity, and auxiliary jack
- Automatic climate control
- Driver and front-passenger auto-up/down power windows
- Cargo-area tray, 4 tie-down hooks and 2 grocery bag hooks
- Front- and rear-passenger seatbelt warning light/chime and rear-seat reminder
- Rear-Vision Camera



### Outback Premium

#### Includes Outback key features and adds:

- Crystal Black Silica finish exterior mirrors with integrated turn signals
- LED rear gate light
- Privacy glass
- All-Weather Package: Heated exterior mirrors, 3-mode heated front seats, windshield wiper de-icer
- 10-way power-adjustable driver seat with 2-way lumbar support
- SUBARU STARLINK 11.6-inch Multimedia Plus with wireless Apple CarPlay<sup>®</sup> and Android Auto<sup>™</sup> integration, SiriusXM<sup>®2</sup> including 4-month Platinum Plan and SiriusXM Travel Link<sup>®2</sup> trial, USB-A and USB-C input ports, 6 speakers, AM/FM stereo, Bluetooth<sup>®</sup> audio streaming, hands-free phone and text messaging connectivity
- 4G LTE Wi-Fi capability<sup>3</sup>
- Single USB-A and USB-C rear-seat charge ports and A/C vents
- Dual-zone automatic climate control system
- Leather-wrapped steering wheel and shifter handle
- Center console 12-volt power outlet
- Lifting and retractable cargo-area cover
- STARLINK Safety and Security enabled<sup>4</sup>: Includes features and services such as Advanced Automatic Collision Notification, Remote Engine Start with Climate Control<sup>5</sup> and Concierge Services



### Outback Onyx Edition

#### Includes Outback Premium key features and adds:

- Dual-Mode X-MODE with Snow/Dirt and Deep Snow/Mud modes
- 18-inch aluminum-alloy wheels with black finish
- Crystal Black Silica front grille
- Black badging and window moldings
- Hands-Free Power Rear Gate with vehicle lock button
- Gray StarTex<sup>®</sup> water-repellent upholstery with green contrast stitching
- Auto-up/down front and rear windows
- Keyless Access with Push-Button Start
- Blind-Spot Detection with Lane Change Assist and Rear Cross-Traffic Alert<sup>6</sup>
- Auto-dimming rearview compass mirror with HomeLink<sup>®</sup>
- 8 cargo-area tie-down hooks

### Outback Onyx Edition XT

#### Includes Outback Onyx Edition features and adds:

- 260-hp 2.4-liter 4-cylinder direct-injection turbocharged SUBARU BOXER engine
- Lineartronic CVT (Continuously Variable Transmission) High Torque with 8-speed manual-mode paddle shifters
- 3,500-lb. towing capacity<sup>7</sup>
- Power moonroof
- Full-size spare tire
- 8-way power-adjustable front-passenger seat
- Heated outboard rear seats
- SUBARU STARLINK 11.6-inch Multimedia Navigation with 3 years of free map updates, SiriusXM<sup>®2</sup> including 4-month Platinum Plan, SiriusXM Traffic<sup>®8</sup> trial and SiriusXM Travel Link<sup>®8</sup> trial
- Reverse Automatic Braking<sup>9</sup>
- 180-Degree Front View Monitor



### Outback Wilderness

#### Includes Outback Premium key features and adds:

- 260-hp 2.4-liter 4-cylinder direct-injection turbocharged SUBARU BOXER engine
- Advanced Dual-Mode X-MODE with Snow/Dirt and Deep Snow/Mud modes, low speed/low ratio gradient control and medium-to-high-speed gravel/dirt functions
- 9.5 inches of ground clearance
- 3,500-lb. towing capacity<sup>7</sup>
- 4 tow points with Anodized Copper-finish covers
- 17-inch aluminum-alloy wheels with matte black finish and Yokohama<sup>®</sup> Geolandar<sup>®</sup> All-Terrain tires
- Hexagonal LED fog lights
- Outback Wilderness-design front and rear bumper covers, fender flares and side cladding
- Outback Wilderness-design front grille
- Matte-black, anti-glare hood decal
- Ladder-style roof rails with increased load-carrying capacity, 4 tie-down points and Anodized Copper-finish accents
- Subaru Wilderness badging on front doors and rear gate
- Black badging and window moldings
- Hands-Free Power Rear Gate with vehicle lock button
- Full-size spare tire
- Outback Wilderness Gray StarTex water-repellent upholstery with Anodized Copper-finish accents and contrast stitching
- Outback Wilderness-design all-weather floor mats
- Outback Wilderness-design cargo-area tray
- Outback Wilderness gauges with color LCD display and Anodized Copper accents
- Aluminum-alloy pedal covers
- 8-way power-adjustable front-passenger seat
- Heated outboard rear seats
- Keyless Access with Push-Button Start
- Blind-Spot Detection with Lane Change Assist and Rear Cross-Traffic Alert<sup>6</sup>
- 180-Degree Front View Monitor
- Auto-dimming rearview compass mirror with HomeLink<sup>®</sup>
- 8 cargo-area tie-down hooks



### Outback Limited

#### Includes Outback Premium key features and adds:

- 18-inch aluminum-alloy wheels
- Silver metallic finish front and rear bumper underguards
- Hands-Free Power Rear Gate with vehicle lock button
- Automatic tilt-down passenger-side mirror
- Keyless Access with Push-Button Start
- Leather-trimmed upholstery
- 12-way power-adjustable driver seat with 4-way lumbar support
- 8-way power-adjustable front-passenger seat
- Adjustable driver-seat thigh support
- Two-position memory driver seat and exterior mirrors
- Heated outboard rear seats
- Harman Kardon<sup>®</sup> 576-watt-equivalent premium audio system with 12 speakers
- Auto-up/down front and rear windows
- Blind-Spot Detection with Lane Change Assist and Rear Cross-Traffic Alert<sup>6</sup>
- Reverse Automatic Braking<sup>9</sup>
- Auto-dimming rearview compass mirror with HomeLink<sup>®</sup>

### Outback Limited XT

#### Includes Outback Limited key features and adds:

- 260-hp 2.4-liter 4-cylinder direct-injection turbocharged SUBARU BOXER engine
- Lineartronic CVT (Continuously Variable Transmission) High Torque with 8-speed manual-mode paddle shifters
- 3,500-lb. towing capacity<sup>7</sup>
- Power moonroof
- Heated steering wheel
- SUBARU STARLINK 11.6-inch Multimedia Navigation with 3 years of free map updates, SiriusXM<sup>®2</sup> including 4-month Platinum Plan, SiriusXM Traffic<sup>®8</sup> trial and SiriusXM Travel Link<sup>®8</sup> trial
- DriverFocus Distraction Mitigation System<sup>10</sup>



### Outback Touring

#### Includes Outback Limited key features and adds:

- Smart auto-dimming rearview compass mirror with HomeLink<sup>®</sup>
- DriverFocus Distraction Mitigation System<sup>10</sup>
- Automatic power-folding exterior mirrors with Satin chrome
- Roof rails with silver finish integrated retractable crossbars and 4 tie-down points
- Body-color door handles with chrome inserts
- Crystal Black Silica finish pillar trim
- 180-Degree Front View Monitor
- Power moonroof
- Nappa leather-trimmed upholstery
- High-grade leather-wrapped steering wheel
- 3-mode ventilated front seats
- Heated steering wheel
- SUBARU STARLINK 11.6-inch Multimedia Navigation with 3 years of free map updates, SiriusXM<sup>®2</sup> including 4-month Platinum Plan, SiriusXM Traffic<sup>®8</sup> trial and SiriusXM Travel Link<sup>®8</sup> trial, and CD player
- 8 cargo-area tie-down hooks

### Outback Touring XT

#### Includes Outback Touring key features and adds:

- 260-hp 2.4-liter 4-cylinder direct-injection turbocharged SUBARU BOXER engine
- Lineartronic CVT (Continuously Variable Transmission) High Torque with 8-speed manual-mode paddle shifters
- 3,500-lb. towing capacity<sup>7</sup>



According to Forbes, Subaru is among the Top 10 Brands consumers love.<sup>11</sup>



The Subaru Outback has the Best Resale Value in its class for three years running, according to Kelley Blue Book's KBB.com.<sup>12</sup>



Subaru is ranked #1 in dependability in the automotive industry.<sup>13</sup>



The Subaru Outback has the lowest 5-Year Cost to Own in its class for 2022, according to Kelley Blue Book's KBB.com.<sup>14</sup>



1 EyeSight is a driver assist technology, which may not operate optimally under all driving conditions. The driver is always responsible for safe and attentive driving. System effectiveness depends on many factors such as vehicle maintenance, weather and road conditions. See your Owner's Manual for complete details on system operation and limitations. 2 All SiriusXM services require a subscription, sold separately by SiriusXM after the trial period. Your SiriusXM service will automatically stop at the end of your trial unless you decide to subscribe. If you decide to continue service, the subscription plan chosen will automatically renew and be charged according to your chosen payment method at the then-current rates. Fees and taxes apply. See the SiriusXM Customer Agreement & Privacy Policy at [www.siriusxm.com](http://www.siriusxm.com) for full terms and how to cancel, which includes online methods or calling 1-866-635-2349. Available in the 48 contiguous United States, D.C., and Puerto Rico (with coverage limits and capable receiver). Visit <http://www.siriusxm.com/FAQS> for most current service area information. Availability of some services and features is subject to device capabilities and location restrictions. All fees, content and features are subject to change. SiriusXM, Pandora and all related logos are trademarks of Sirius XM Radio Inc. and its respective subsidiaries. 3 Activation and subscription required. Internet access is purchased separately through AT&T with monthly, per gigabyte, and unlimited data options available. Existing AT&T customers have the option to add a line to their AT&T Mobile Share plan. See your retailer for details. 4 Activation with subscription required. Includes a 3-year trial subscription to STARLINK Safety Plus services and a 6-month trial subscription to STARLINK Safety and Security Plus services. The Concierge plan can be purchased annually or monthly. A credit card on file will be required for specific packages and for renewal purposes. Not available in all states. See your retailer for details. 5 Requires Keyless Access with Push-Button Start. See your retailer for details. 6 Blind-Spot Detection, Lane Change Assist and Rear Cross-Traffic Alert are systems designed to assist the driver by monitoring the rear and side areas of the vehicle during a lane change or reversing and are not a substitute for safe and attentive driving. 7 Trailer brakes may be needed. Some safety features, including X-MODE, Blind-Spot Detection and Rear Cross-Traffic Alert, may not function properly when towing. See your retailer for details. 8 Activation and monthly subscription sold separately. Includes 3-year trial subscription. See your retailer for details. 9 The Reverse Automatic Braking System is not a substitute for safe and attentive driving. System effectiveness depends on many factors, such as vehicle maintenance, weather and road conditions. Always exercise caution and use vehicle mirrors and the Rear-Vision Camera when backing up. See your Owner's Manual for complete details on system operation and limitations. 10 The DriverFocus Distraction Mitigation System is a driver recognition technology designed to alert drivers if their attention to the road wavers or if the driver's face appears to turn away. The driver is always responsible for safe and attentive driving. System effectiveness may be affected by articles of clothing worn on the head or face. See your Owner's Manual for complete details on system operation and limitations. 11 Based on Forbes 2022 Halo 100, powered by HundredX. 12 Vehicle's projected resale value is specific to the 2020-2022 model years. For more information, visit Kelley Blue Book's KBB.com. Kelley Blue Book is a registered trademark of Kelley Blue Book Co., Inc. 13 2021 American Customer Satisfaction Index Survey of customers rating the performance of their own automobiles. 14 2022 model-year vehicle's projected cost to own for the initial five-year ownership period is based on the average Kelley Blue Book 5-Year Cost to Own data, which considers depreciation and costs such as fuel and insurance. For more information, visit [www.kbb.com](http://www.kbb.com).



## 2023 Outback | Specifications

Engine and Drivetrain		Outback	Outback XT
<b>Engine Power   Torque</b>	2.5-liter DOHC direct-injection aluminum-alloy 16-valve 4-cylinder horizontally opposed SUBARU BOXER engine with Dual Active Valve Control System (DAVCS). 182 hp @ 5,800 rpm   176 lb-ft @ 4,400 rpm	●	—
	2.4-liter DOHC, Direct Injection Turbocharged (DIT), intercooled, aluminum-alloy 16-valve 4-cylinder horizontally opposed SUBARU BOXER engine with Dual Active Valve Control System (DAVCS). 260 hp @ 5,600 rpm   277 lb-ft @ 2,000–4,800 rpm	—	●
<b>Auto Start-Stop System</b>	Automatically turns off and restarts the vehicle's engine when stopped, reducing vehicle idle time, emissions and fuel consumption.	●	●
<b>Automatic Transmission</b>	Lineartronic CVT (Continuously Variable Transmission) with Adaptive Control and 8-speed manual mode with paddle shifters.	●	—
	Lineartronic CVT (Continuously Variable Transmission) High Torque with Adaptive Control and 8-speed manual mode with paddle shifters.	—	●
<b>CA Emissions</b>		LEV III/SULEV 30	LEV III/ULEV 50
<b>Maximum Towing Capacity<sup>1</sup> (certain limitations apply)</b>		2,700 lbs.	3,500 lbs.
Traction and Stability			
<b>All-Wheel Drive type</b>	Subaru Symmetrical All-Wheel Drive	●	●
<b>X-MODE</b>	X-MODE optimizes engine output and transmission ratio, increases all-wheel drive system engagement and uses enhanced control of the VDC system to reduce or increase individual wheelspin, providing optimal traction on various types of terrain and low friction surfaces. <b>Outback, Outback Premium, Outback Limited/XT and Outback Touring/XT:</b> Standard. Single-mode system. <b>Outback Onyx Edition/XT:</b> Standard. Dual-mode system with Snow/Dirt and Deep Snow/Mud modes. <b>Outback Wilderness:</b> Advanced dual-mode system with Snow/Dirt and Deep Snow/Mud modes, low speed/low ratio gradient control and medium-to-high-speed gravel/dirt functions.	●	●
<b>Hill Descent Control (HDC)</b>	X-MODE also incorporates Hill Descent Control that helps to maintain a constant vehicle speed when traveling downhill, enhancing vehicle control.	●	●
<b>Vehicle Dynamics Control (VDC)</b>	VDC electronic stability control utilizes sensors that constantly monitor wheel speeds, steering angle, brake pressure, vehicle yaw rate and lateral g-forces. If VDC detects a difference between the driver's intended path and the one the vehicle is actually taking, VDC applies braking power and/or reduces engine torque to help correct vehicle path.	●	●
<b>Traction Control System (TCS)</b>	VDC also incorporates an all-wheel, all-speed Traction Control System, which senses a loss of traction and applies braking force to the slipping wheel or wheels as necessary to maintain vehicle motion.	●	●
<b>Active Torque Vectoring</b>	Active Torque Vectoring works in tandem with VDC to apply braking power to the inside wheels, resulting in better handling, sharper turn-in, more neutral steering and higher cornering limits when turning.	●	●

## 2023 Outback | Specifications

Traction and Stability (continued)		Outback	Outback XT
<b>Auto Vehicle Hold (AVH)</b>	AVH helps to reduce driver fatigue by holding the vehicle in place when the vehicle is stopped, after the brake pedal has been released. Utilizing VDC and the Electronic Parking Brake, AVH can hold the vehicle stationary on level, decline or incline surfaces.	●	●
Fuel			
<b>Fuel Economy</b>	city/highway/combined <sup>2</sup>	26/32/28 mpg	22/29/25 mpg Outback Wilderness: 21/26/23 mpg
<b>Fuel Requirement</b>	Unleaded gasoline (87 octane)	●	●
<b>Fuel Capacity</b>	18.5 gallons	●	●
Chassis			
<b>Steering</b>	Electric power-assisted quick ratio rack-and-pinion steering (EPAS). Turning circle: 36.1 feet.	●	●
<b>Suspension</b>	4-wheel independent raised suspension. <b>Front:</b> Strut type with internal rebound spring. Aluminum-alloy lower L-arm. Stabilizer bar. <b>Rear:</b> Double-wishbone. Stabilizer bar.	●	●
<b>Brakes</b>	4-wheel disc. Ventilated front and rear. 4-channel, 4-sensor ABS with Electronic Brake-force Distribution (EBD).	●	●
<b>Brake Discs (front/rear)</b>	12.4 inches/11.8 inches	●	●
<b>Brake Override System</b>	If both brake and accelerator pedals are pressed simultaneously, the system reduces the operation of the accelerator pedal to help prevent unintentional vehicle acceleration.	●	●
Wheels and Tires			
<b>Wheels</b>	<b>Outback and Outback Premium:</b> 17 x 7.0-inch aluminum-alloy. Black with machine finish.	●	—
	<b>Outback Onyx Edition/XT:</b> 18 x 7.0-inch aluminum-alloy. Black finish.	●	●
	<b>Outback Wilderness:</b> 17 x 7.0-inch aluminum-alloy. Matte black finish.	—	●
	<b>Outback Limited/XT and Outback Touring/XT:</b> 18 x 7.0-inch aluminum-alloy. Black with machine finish.	●	●
<b>Tires</b>	<b>Outback and Outback Premium:</b> 225/65 R17 102H All-season.	●	—
	<b>Outback Onyx Edition/XT, Outback Limited/XT and Outback Touring/XT:</b> 225/60 R18 100H All-season.	●	●
	<b>Outback Wilderness:</b> 225/65 R17 102T All-terrain with raised white letters.	—	●

● Standard ○ Optional — Not equipped

## 2023 Outback | Equipment

Exterior	Outback	Outback Premium	Outback Onyx Ed. / XT	Outback Wilderness	Outback Limited / XT	Outback Touring / XT
LED Steering Responsive Headlights (SRH) with High Beam Assist (HBA)	●	●	●	●	●	●
LED fog lights (Outback Wilderness: Hexagonal style)	●	●	●	●	●	●
Silver metallic finish front and rear bumper underguards	□	□	—	—	●	●
Black folding exterior mirrors (Outback Wilderness: with integrated turn signals and black trim)	●	—	—	●	—	—
Crystal Black Silica exterior mirrors with integrated turn signals	—	●	●	—	●	—
Automatic tilt-down passenger-side mirror	—	—	—	—	●	●
Heated exterior mirrors and windshield wiper de-icer (All-Weather Package)	—	●	●	●	●	●
Power tilt/sliding-glass moonroof (95% UV light-reducing) <sup>3,4</sup>	—	○	○ / ●	○	○ / ●	●
Roof rails with integrated retractable crossbars and 4 tie-down points (150-lb. dynamic maximum load capacity)	●	●	●	—	●	●
<b>Seating and Trim</b>						
6-way manually adjustable driver seat	●	—	—	—	—	—
10-way power-adjustable driver seat with 2-way adjustable lumbar support	—	●	●	●	—	—
12-way power-adjustable driver seat with 4-way adjustable lumbar support	—	—	—	—	●	●
4-way manually adjustable front-passenger seat	●	●	● / —	—	—	—
8-way power-adjustable front-passenger seat	—	—	— / ●	●	●	●
Adjustable driver-seat thigh support	—	—	—	—	●	●
Heated front seats (All-Weather Package)	—	●	●	●	●	●
Heated outboard rear seats	—	—	— / ●	●	●	●
3-mode ventilated front seats	—	—	—	—	—	●
360-degree heated steering wheel	—	—	—	—	○ <sup>4</sup> / ●	●
Reclining, one-touch 60/40-split flat-folding rear seatback	●	●	●	●	●	●
<b>Convenience Features</b>						
Keyless Access with Push-Button Start	—	○ <sup>4</sup>	●	●	●	●
Hands-Free Power Rear Gate with automatic close, height memory function and vehicle lock button	—	○ <sup>4</sup>	●	●	●	●
LED rear gate light	—	●	●	●	●	●
2-position memory driver seat and exterior mirrors	—	—	—	—	●	●
Auto-dimming rearview compass mirror with HomeLink®	□	□	●	●	●	—
Smart auto-dimming rearview compass mirror with HomeLink®	—	—	—	—	—	●
Driver and front-passenger auto-up/down power windows	●	●	●	●	●	●
Rear seat auto-up/down power windows	—	—	●	●	●	●
4G LTE Wi-Fi capability <sup>5</sup>	—	●	●	●	●	●
Illuminated USB-A and USB-C front input ports and rear charge ports	—	●	●	●	●	●
8 cup and bottle holders	●	●	●	●	●	●
Cargo-area tray	●	●	●	●	●	●
Lifting and retractable cargo-area cover	□	●	●	●	●	●
<b>Audio and Communication Systems</b>						
SUBARU STARLINK Dual 7.0-inch Multimedia with Apple CarPlay® and Android Auto™ integration, SiriusXM® including 4-month Platinum Plan and SiriusXM Travel Link® trial, USB-A input port, 4 speakers, AM/FM stereo, HD Radio®, Bluetooth® audio streaming, hands-free phone and text messaging connectivity	●	—	—	—	—	—
SUBARU STARLINK 11.6-inch Multimedia Plus with wireless Apple CarPlay® and Android Auto™ integration, SiriusXM® including 4-month Platinum Plan and SiriusXM Travel Link® trial, USB-A and USB-C input ports, AM/FM stereo, HD Radio®, Bluetooth® audio streaming, hands-free phone and text messaging connectivity	—	●	● / —	●	● / —	—
SUBARU STARLINK 11.6-inch Multimedia Navigation System with 3 years of free map updates, wireless Apple CarPlay® and Android Auto™ integration, SiriusXM® including 4-month Platinum Plan, SiriusXM Traffic® trial and SiriusXM Travel Link® trial, USB-A and USB-C input ports, AM/FM stereo, HD Radio®, Bluetooth® audio streaming, hands-free phone and text messaging connectivity	—	○ <sup>4</sup>	○ <sup>4</sup> / ●	○ <sup>4</sup>	○ <sup>4</sup> / ●	●
6 speakers	—	●	●	●	—	—

## 2023 Outback | Equipment

Audio and Communication Systems (continued)	Outback	Outback Premium	Outback Onyx Ed. / XT	Outback Wilderness	Outback Limited / XT	Outback Touring / XT
Harman Kardon® premium system with 576-watt-equivalent amplifier and 12 speakers, including center dash speaker and subwoofer	—	—	—	—	●	●
<b>Climate Control</b>						
Automatic climate control system with air filtration	●	—	—	—	—	—
Dual-zone automatic climate control system with air filtration	—	●	●	●	●	●
<b>Instrumentation</b>						
Analog speedometer, tachometer, coolant temperature and fuel level gauges. LCD color screen, displaying vehicle functions.	●	●	●	●	●	●
<b>Security</b>						
Keyless entry system with answer-back electronic chirp	●	●	●	●	●	●
Anti-theft security system with engine immobilizer	●	●	●	●	●	●
<b>Safety</b>						
<b>ACTIVE</b>						
Subaru Symmetrical All-Wheel Drive (AWD)	●	●	●	●	●	●
EyeSight Driver Assist Technology <sup>8</sup> : Pre-Collision Braking System, Pre-Collision Throttle Management, Lane Departure and Sway Warning, Advanced Adaptive Cruise Control with Lane Centering, Automatic Emergency Steering <sup>9</sup>	●	●	●	●	●	●
Blind-Spot Detection with Lane Change Assist and Rear Cross-Traffic Alert <sup>10</sup>	—	○ <sup>4</sup>	●	●	●	●
Reverse Automatic Braking (RAB) <sup>11</sup>	—	—	○ <sup>4</sup> / ●	○ <sup>4</sup>	●	●
DriverFocus Distraction Mitigation System (DMS) <sup>12</sup>	—	—	—	—	○ <sup>4</sup> / ●	●
Tire Pressure Monitoring System (TPMS)	●	●	●	●	●	●
LED Daytime Running Lights (DRL)	●	●	●	●	●	●
180-Degree Front View Monitor	—	—	— / ●	●	—	●
Rear-Vision Camera with washer	●	●	●	●	●	●
<b>PASSIVE</b>						
STARLINK Safety and Security enabled <sup>13</sup> : Advanced Automatic Collision Notification, SOS Emergency Assistance, Enhanced Roadside Assistance, Maintenance Notifications, Vehicle Health Reports, Diagnostic Alerts, Remote Engine Start with Climate Control, <sup>14</sup> Remote Lock/Unlock, Concierge Services and more	—	●	●	●	●	●
Subaru advanced frontal airbag system with dual-stage deployment driver and front-passenger airbags (SRS) <sup>15</sup>	●	●	●	●	●	●
Driver's knee airbag (SRS) <sup>15</sup>	●	●	●	●	●	●
Front-passenger seat cushion airbag (SRS) <sup>15</sup>	●	●	●	●	●	●
Side-curtain airbags with rollover sensor protecting front and rear outboard occupants (SRS) <sup>15</sup>	●	●	●	●	●	●
Seat-mounted front side-impact airbags (SRS) <sup>15</sup>	●	●	●	●	●	●
Whiplash-reducing front seats with height-adjustable head restraints	●	●	●	●	●	●
Height-adjustable 3-point front seatbelts with pretensioners and force limiters	●	●	●	●	●	●
3-point seatbelts at all rear seating positions	●	●	●	●	●	●
Front/rear passenger seatbelt warning light/chime, rear-seat reminder and child-safety rear door locks	●	●	●	●	●	●
LATCH system: Lower Anchors and Tethers for CHildren	●	●	●	●	●	●
<b>Optional Equipment</b>						
Keyless Access with Push-Button Start • Hands-Free Power Rear Gate • Blind-Spot Detection with Lane Change Assist and Rear Cross-Traffic Alert <sup>10</sup> • Automatic Emergency Steering <sup>9</sup>	—	○	—	—	—	—
Keyless Access with Push-Button Start • Hands-Free Power Rear Gate • Blind-Spot Detection with Lane Change Assist and Rear Cross-Traffic Alert <sup>10</sup> • Automatic Emergency Steering <sup>9</sup> • Power moonroof • SUBARU STARLINK 11.6-inch Multimedia Navigation System	—	○	—	—	—	—
Power moonroof • SUBARU STARLINK 11.6-inch Multimedia Navigation System • Reverse Automatic Braking <sup>11</sup>	—	—	○ / ●	○	—	—
Power moonroof • SUBARU STARLINK 11.6-inch Multimedia Navigation System • DriverFocus Distraction Mitigation System <sup>12</sup> • Heated steering wheel	—	—	—	—	○ / ●	—

● Standard ○ Optional — Not equipped □ Available retailer-installed accessory

## Outback | Accessories



**Thule® Portable Step.** Get the extra height you need to easily access your rooftop accessories. The Thule® Portable Step is made of heavy duty steel and includes rubber bumpers to help prevent wheel scrapes and scuffs. Conveniently folds into a carrying bag for easy storage.



**Wireless Charger.** No untangling required. The Wireless Charger is a Qi Certified Device with Intelligent Charging Profiles, battery protection, temperature control and short circuit safe guards. Works with all Qi and Samsung Fast Charge enabled devices. Anti-slip rubber insert keeps your device in place.



**Rear Seatback Protector.** Provides additional protection to the rear seatback when lowering the seats to transport larger cargo.

Use in conjunction with the Cargo Tray for maximum protection.



**Auto-Dimming Exterior Mirrors with Approach Light.** Designed to enhance nighttime driving safety by working in unison with the Auto-Dimming (Interior) Mirror to reduce headlight glare. Upon approaching the vehicle or unlocking your doors with the keyless entry system, LED lights in each exterior mirror illuminate the ground next to and towards the rear of the vehicle.

Requires Auto-Dimming (Interior) Mirror.

**Subaru Loves Pets™**

Introducing Genuine Subaru Pet-friendly Accessories.

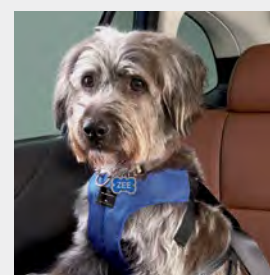

**Pet Harness.** Keep your dog safe with this crash-tested Pet Harness, certified by the Center for Pet Safety for dogs from 18 to 90 pounds. Manufactured by Sleepypod® in signature Subaru blue, the Pet Harness can also be used for walking your dog. Available in S, M, L or XL.

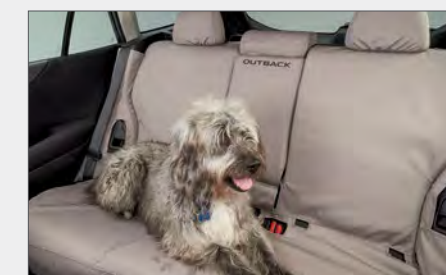

**Seat Cover – Rear.** Keep your second row tidy with this custom-fitted seat cover, made with water-resistant heavy-duty materials.



**Console Lid Protector.** Protects the center console lid surface from nail scratches and puncture holes, while providing a comfortable armrest for front-seat passengers.



**License Plate Frame – Pet Lover.** Share your love for your furry, scaly or feathered friends with our Pet Lover license plate frame. Available in either matte black or polished stainless steel.



**Pet-friendly Padded Cargo Liner.** Thick padding and a durable polyester shell provides a comfortable resting area for your pet while protecting the cargo and seatback areas. This accessory includes a foldout bumper protector and is compatible with the 60/40 seats up or down.



**Pet Carrier and Mobile Pet Bed.** This multi-functional ultra-plush pet bed also doubles as a carrier to safely transport your pet in comfort. Manufactured by Sleepypod®, this accessory is crash-tested and certified by the Center for Pet Safety.

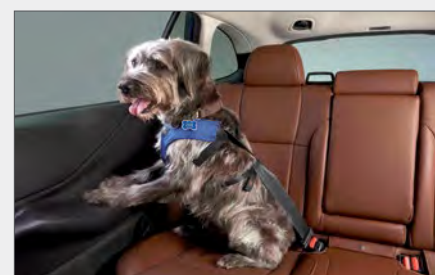

**Pet Rear Door Protector.** If you're bringing along your furry companion, this lightweight, durable Pet Rear Door Protector helps keep your door panel free from scratches, scuffs and, yes, even drool. Manufactured with heavy-duty polyester and designed to seamlessly fit the contours of your door. Comes in a set of two.



**Collapsible Pet Kennel.** Portable, compact and lightweight, the Collapsible Pet Kennel, manufactured by Thule®, is ideal for travel and for everyday transport. Includes a carrying handle for easy transport and two pockets to carry your pet's personal cargo.



**Cargo Net.** Neatly holds cargo and prevents it from sliding while the vehicle is in motion. The Cargo Net can be used two ways: anchor it to the sides of the cargo area to help prevent shifting from front to back or lay it across the floor to help keep things from rolling around.



**Cargo Sidewall Protector.** Durably constructed to protect the rear cargo area and wheel well trim panels. Engineered for precise fit and can be easily removed for cleaning. The Cargo Sidewall Protectors provide optimal protection when used in conjunction with the Rear Seatback Protector and factory-installed Cargo Tray. Set of two.



**Door Scuff Protector:** A durable, easy-to-clean plastic shell that protects your doors from common scuffs and scrapes. The unique texture compliments the design of the Outback. Comes in a set of four.



**Mud Flaps.** Provides a protective barrier to help protect your Outback from the elements while also preventing minor road debris from kicking up behind your vehicle. Durably constructed and designed to minimize water, dirt and mud spray. Includes the Outback logo. Special edition designed for Outback Wilderness includes a stylish mountain scene molded into the lower portion of the product.

For a complete list of available accessories, visit your local Subaru retailer or visit [www.subaru.com](http://www.subaru.com)

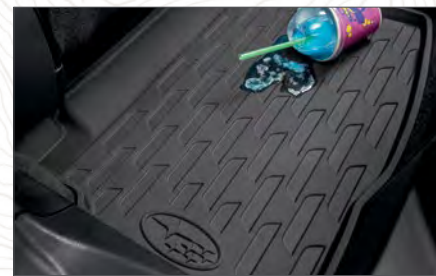

**All-Weather Floor Liners.** Custom-fitted, high-wall floor liners help protect carpeting from spills, snow, sand, mud, dirt and moisture. Liners are engineered for a precise fit and tested for durability.



**Remote Engine Starter.** Lets you start the Outback from a distance of up to 400 feet (depending on obstructions), allowing the interior to reach a more comfortable temperature upon entry. This Genuine Subaru Accessory is an alternative for customers who do not enroll in STARLINK Safety and Security Plus.



**Body Side Molding.** Attractive color-matched moldings coordinate with the styling of the vehicle while helping to protect doors from unsightly dings.



**Trailer Hitch.** Engineered and crash tested to meet the same rigorous safety standards as the rest of the Outback. Heavy-duty 2-inch receiver rated at 3,500 lbs. towing capacity, 350 lbs. tongue weight for the 2.4L Turbo XT and Outback Wilderness models, and 2,700 lbs. towing capacity, 270 lbs. tongue weight for the naturally aspirated 2.5L.

Trailer hitch requires the hitch and harness for proper operation and safety compliance. Hitch ball not included.



Thule® Bike Carrier – Roof Mounted



Thule® Cargo Carrier – Extended



Thule® Heavy-Duty Roof Cargo Basket

## Outfit your Outback.

When your passion is even bigger than your cargo area, Genuine Subaru active lifestyle accessory attachments manufactured by Thule® are a smart way to securely transport larger gear like bikes, skis, snowboards, kayaks, paddleboards and more. Each carrier safely attaches to your roof rack, and the available Thule® Portable Step can help you easily access everything.

## 2023 Outback | Owner Benefits

For additional Subaru resources, including owner's manuals, maintenance schedules, roadside assistance and more, log on to [www.mysubaru.com](http://www.mysubaru.com)

### Protecting Your Investment

Once you're part of our family, we'll be there for you. Every Subaru comes with 24-hour roadside assistance for 3 years or 36,000 miles. If you have trouble on the road, a tow to the nearest Subaru retailer and other services are just a phone call away. And to protect you over the long haul, we offer Added Security<sup>®</sup> (ask for it by name). It includes extended service agreements and maintenance plans to help protect your car for up to 10 years or 100,000 miles. They're the only mechanical and maintenance plans backed by Subaru, and because we've been backing them for more than 30 years, they're agreements you can trust. Your retailer has full coverage details.



000475 038000 102000 157000 248000

### More Than a Car Company<sup>®</sup>



Love means being more than a car company. The **Subaru Love Promise<sup>®</sup>** is our vision to show love and respect to all people at every interaction with Subaru. Together with our retailers, we are dedicated to making the world a better place.

### Warranties

**New Car Limited Warranty** 3 years or 36,000 miles, whichever comes first.

**Powertrain Limited Warranty** 5 years or 60,000 miles, whichever comes first.

**Wear Item Limited Warranty** 3 years or 36,000 miles, whichever comes first.

- Brake Pads
- Wiper Blades
- Clutch Linings
- Transmitter Batteries

Repairs to the following items will also be covered under Wear Item Limited Warranty:

**Rust Perforation Limited Warranty** 5 years, unlimited mileage.

**24-hour Roadside Assistance** 3 years or 36,000 miles, whichever comes first.

1 Trailer brakes may be needed. Some safety features, including X-MODE, Blind-Spot Detection and Rear Cross-Traffic Alert, may not function properly when towing. See your retailer for details. 2 2023 EPA fuel economy estimates. Actual mileage may vary. 3 The glass information listed represents calculated reference values and may not represent actual values determined by testing. 4 Available only with other features. See Optional Equipment listing. 5 Activation and subscription required. Internet access is purchased separately through AT&T with monthly, per gigabyte, and unlimited data options available. Existing AT&T customers have the option to add a line to their AT&T Mobile Share plan. See your retailer for details. 6 All SiriusXM services require a subscription, sold separately by SiriusXM after the trial period. Your SiriusXM service will automatically stop at the end of your trial unless you decide to subscribe. If you decide to continue service, the subscription plan chosen will automatically renew and be charged according to your chosen payment method at the then-current rates. Fees and taxes apply. See the SiriusXM Customer Agreement & Privacy Policy at [www.siriusxm.com](http://www.siriusxm.com) for full terms and how to cancel, which includes online methods or calling 1-866-635-2349. Available in the 48 contiguous United States, D.C., and Puerto Rico (with coverage limits and capable receiver). Visit <http://www.siriusxm.com/FAQS> for most current service area information. Availability of some services and features is subject to device capabilities and location restrictions. All fees, content and features are subject to change. SiriusXM, Pandora and all related logos are trademarks of Sirius XM Radio Inc. and its respective subsidiaries. 7 Activation and monthly subscription sold separately. Includes 3-year trial subscription. See your retailer for details. 8 EyeSight is a driver assist technology, which may not operate optimally under all driving conditions. The driver is always responsible for safe and attentive driving. System effectiveness depends on many factors such as vehicle maintenance, weather and road conditions. The Pre-Collision Braking System is designed to provide automatic braking that either prevents a collision or reduces the severity of a frontal impact. Pre-Collision Throttle Management is designed to reduce acceleration and minimize the severity of certain frontal impacts. Advanced Adaptive Cruise Control, Brake Light Recognition and Automatic Emergency Steering are designed to assist the driver and are not substitutes for safe and attentive driving. Automatic Emergency Steering availability varies by trim level and works in conjunction with and after Pre-Collision Braking has been activated by providing steering support at speeds lower than 50 mph to try and help avoid a collision. Lane centering function operates only when used in conjunction with Advanced Adaptive Cruise Control. The Lane Departure and Sway Warning operates only when the lane markings are visible, and its effectiveness depends on many factors. See your Owner's Manual for complete details on system operation and limitations. 9 Automatic Emergency Steering requires Blind-Spot Detection. Optional on Premium trim. See Optional Equipment listing. 10 Blind-Spot Detection, Lane Change Assist and Rear Cross-Traffic Alert are systems designed to assist the driver by monitoring the rear and side areas of the vehicle during a lane change or reversing and are not a substitute for safe and attentive driving. 11 The Reverse Automatic Braking System is not a substitute for safe and attentive driving. System effectiveness depends on many factors, such as vehicle maintenance, weather and road conditions. Always exercise caution and use vehicle mirrors and the Rear-Vision Camera when backing up. See your Owner's Manual for complete details on system operation and limitations. 12 The DriverFocus Distraction Mitigation System is a driver recognition technology designed to alert drivers if their attention to the road wavers or if the driver's face appears to turn away. The driver is always responsible for safe and attentive driving. System effectiveness may be affected by articles of clothing worn on the head or face. See your Owner's Manual for complete details on system operation and limitations. 13 Activation with subscription required. Includes a 3-year trial subscription to STARLINK Safety Plus services and a 6-month trial subscription to STARLINK Safety and Security Plus services. The Concierge plan can be purchased annually or monthly. A credit card on file will be required for specific packages and for renewal purposes. Not available in all states. See your retailer for details. 14 Requires Keyless Access with Push-Button Start. See your retailer for details. 15 The Supplemental Restraint System (SRS) (airbags) aids the driver and the front passenger additional protection in moderate to severe frontal and side-impact collisions and outboard 2nd-row passengers additional protection in moderate to severe side-impact collisions. This system provides supplemental protection only, and seatbelts must be worn in order to avoid injuries to out-of-position occupants upon airbag deployment and to provide the best combined protection in a serious accident. Children should always be properly restrained in one of the rear seats. See your Owner's Manual for recommended seating position. 16 Based on Experian Automotive vehicles in operation vs. total new registrations for MY2012-2021 as of December 2021.

## 2023 Outback | Dimensions

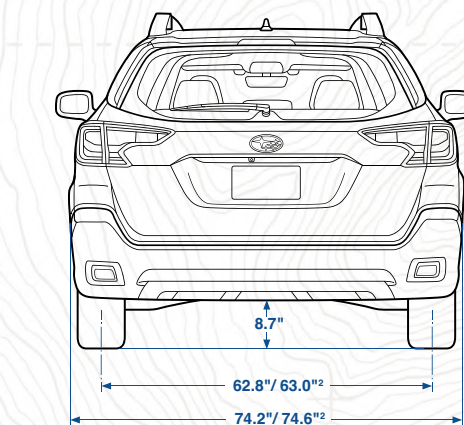
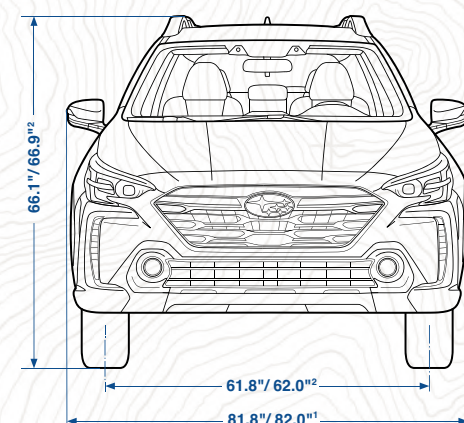
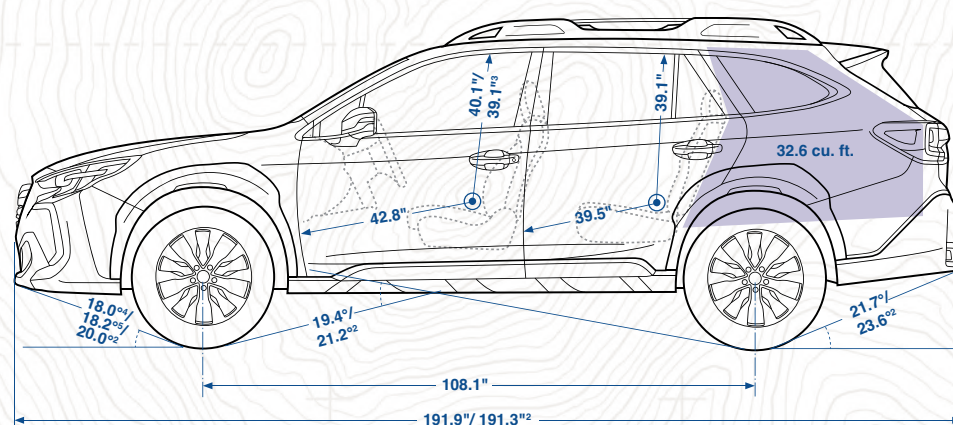
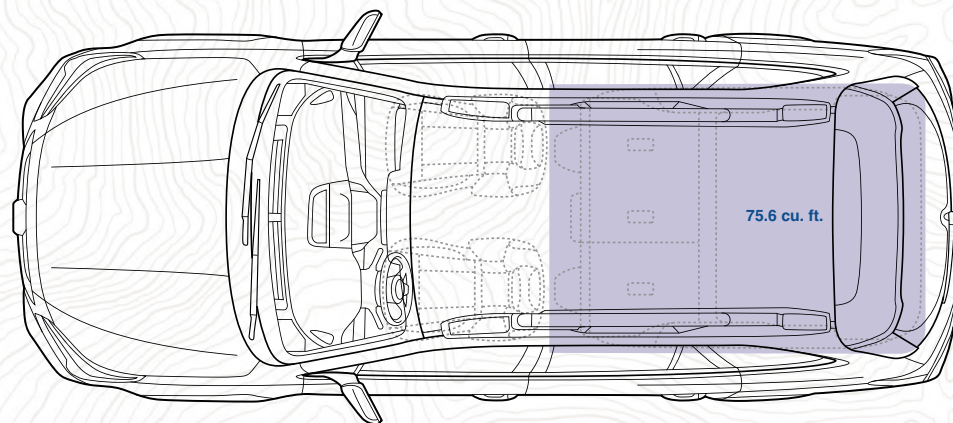

**Length** 191.9 inches  
Outback Wilderness: 191.3 inches

**Width** 74.2 inches, Outback Wilderness: 74.6 inches  
(81.8 inches/82.0 inches,<sup>1</sup> including mirrors)

**Height** 66.1 inches  
Outback Wilderness: 66.9 inches

**Wheelbase** 108.1 inches

**Track (front/rear)** 61.8 inches/62.8 inches  
Outback Wilderness: 62.0 inches/63.0 inches

**Base curb weight** **Outback:** 3,641 lbs.  
**Outback Premium:** 3,661 lbs.  
**Outback Onyx Edition:** 3,692 lbs.  
**Outback Limited:** 3,735 lbs.  
**Outback Touring:** 3,781 lbs.  
**Outback Onyx Edition XT:** 3,921 lbs.  
**Outback Wilderness:** 3,902 lbs.  
**Outback Limited XT:** 3,931 lbs.  
**Outback Touring XT:** 3,946 lbs.

**Ground clearance** 8.7 inches (at curb weight)  
Outback Wilderness: 9.5 inches (at curb weight)

**Approach angle** 18.0<sup>2</sup>/18.2<sup>2</sup>/ Outback Wilderness: 20.0<sup>2</sup>

**Departure angle** 21.7<sup>2</sup>/ Outback Wilderness: 23.6<sup>2</sup>

**Breakover angle** 19.4<sup>2</sup>/ Outback Wilderness: 21.2<sup>2</sup>

**Headroom (front/rear)** 40.1 inches/39.1 inches  
(with available moonroof: 39.1 inches/39.1 inches)

**Legroom (front/rear)** 42.8 inches/39.5 inches

**Shoulder room (front/rear)** 58.1 inches/57.4 inches

**Hip room (front/rear)** 55.5 inches/54.8 inches

**Passenger volume** 109.0 cubic feet  
(with available moonroof: 107.5 cubic feet)

**Cargo volume** 32.6 cubic feet

**Maximum cargo volume** 75.6 cubic feet with rear seatback folded

1 With integrated turn signals. 2 Outback Wilderness trim level. 3 With available moonroof. 4 18.2 degrees for Outback, Outback Premium and Outback Onyx Edition XT trim levels. 18.0 degrees for Limited, Touring, Limited XT and Touring XT trim levels.

Some images shown are for illustration purposes only. Specifications and imagery in this brochure are based on the latest product information available at the time of publication. Production models may vary. For the most up-to-date and detailed product information, log on to [www.subaru.com](http://www.subaru.com). Some equipment shown in photography in this brochure is optional at extra cost. Specific options may be available only in combination with other options. Specific combinations of equipment or features may vary from time to time and by geographic area. Certain accessories and equipment may not be available at the time of publication. Subaru of America, Inc., reserves the right to change or discontinue at any time, without notice, prices, colors, materials, equipment, accessories, specifications, models and packages without incurring any obligation to make the same or similar changes on vehicles previously sold. Colors shown may vary due to reproduction and printing processes.

This brochure was prepared by Subaru of America, Inc. A warranty from Subaru of America, Inc., is available only on cars sold to the first retail purchaser through an authorized Subaru retailer in the continental U.S. or Alaska. Every owner of the car during the warranty period shall be entitled to the benefit of these warranties. Subaru, SUBARU BOXER, SUBARU STARLINK, STARLINK, EyeSight, Wilderness, Lineartronic and X-MODE are registered trademarks of Subaru Corporation. Added Security, DriveFocus, Love, Love Promise, More Than a Car Company, Outback and StarTex are registered trademarks of Subaru of America, Inc. Subaru Loves Pets is a trademark of Subaru of America, Inc. Android Auto<sup>™</sup> is a trademark of Google LLC. Apple CarPlay<sup>™</sup> and iPod<sup>™</sup> are registered trademarks of Apple Inc. Bluetooth<sup>™</sup> is a registered trademark of Bluetooth SIG, Inc. Harman Kardon<sup>™</sup> is a registered trademark of Harman International Industries, Inc. HD Radio<sup>®</sup> is a registered trademark of iBiquity Digital Corporation. HomeLink<sup>®</sup> and the HomeLink house icon are registered trademarks of Gentex Corporation. SiriusXM<sup>®</sup>, Traffic<sup>™</sup> and Travel Link<sup>™</sup> are registered trademarks of SiriusXM Radio Inc. Thule<sup>®</sup> is a registered trademark of the Thule Group. Yokohama<sup>®</sup> and Geolandar<sup>®</sup> are registered trademarks of Yokohama Tire Company. For more information, contact your Subaru retailer, or log on to [www.subaru.com](http://www.subaru.com).

## 2023 Outback | Colors

### Paint

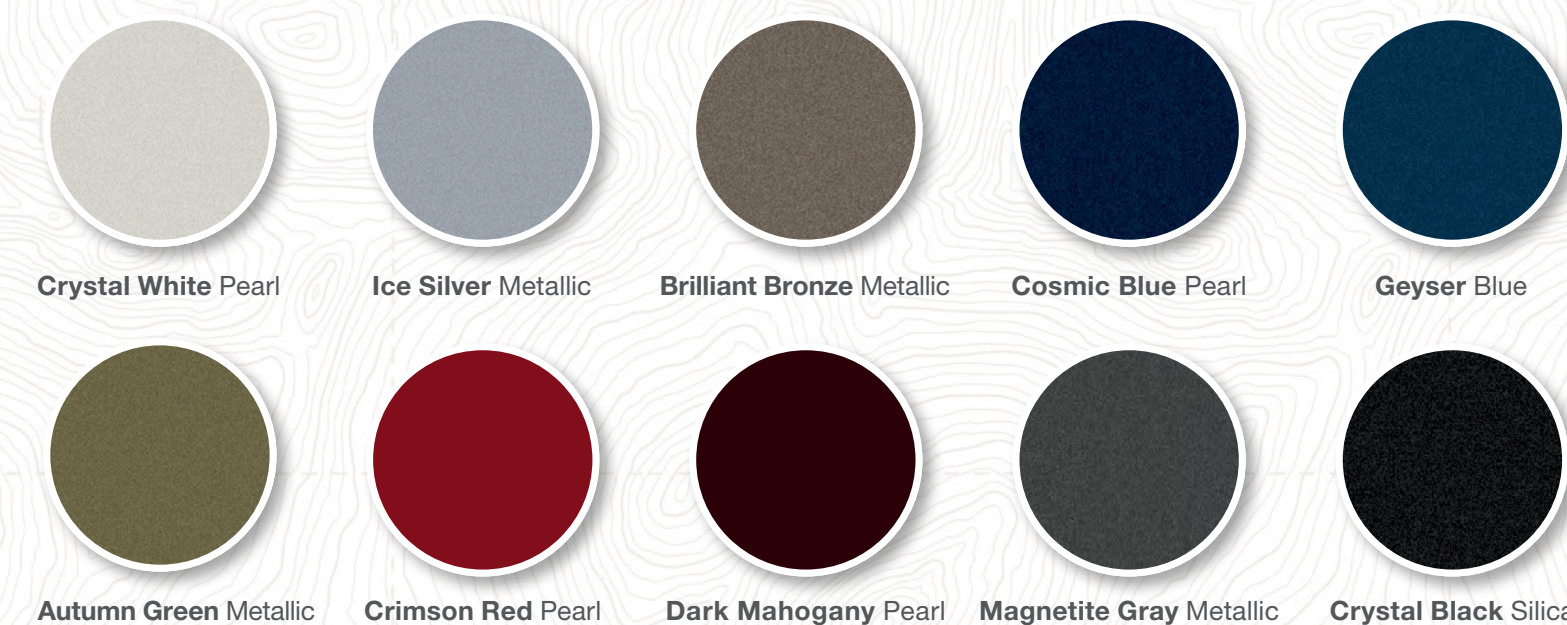

### Upholstery



### Color Combinations

	Outback	Outback Premium	Outback Onyx Edition/XT	Outback Wilderness	Outback Limited/Limited XT	Outback Touring/Touring XT
Crystal White Pearl	SBC	SBC or TGC	GST	GS2	SBL or WIL	JNL or SNL
Ice Silver Metallic	SBC	SBC or TGC	GST	GS2	SBL or TGL	SNL
Brilliant Bronze Metallic	—	SBC	—	—	SBL	—
Cosmic Blue Pearl	SBC	SBC or TGC	GST	—	SBL or TGL	JNL or SNL
Geyser Blue	—	—	—	GS2	—	—
Autumn Green Metallic	—	SBC or WIC	GST	GS2	SBL or WIL	JNL or SNL
Crimson Red Pearl	—	SBC	—	—	SBL	SNL
Dark Mahogany Pearl	—	—	—	—	SBL	SNL
Magnetite Gray Metallic	SBC	SBC or TGC	GST	GS2	SBL or TGL	JNL or SNL
Crystal Black Silica	SBC	SBC or TGC	GST	GS2	SBL or WIL	JNL or SNL

— Not available

OUTBACK  
XT

These brochures were printed with vegetable-based inks and produced using a "Green Printing Process." The Forest Stewardship Council® (FSC®) is an international organization that brings people together to find solutions which promote responsible stewardship of the world's forests and environments.

By producing these brochures in a green way rather than by traditional methods, we saved 83 trees preserved for the future; 18,000 gallons of wastewater flow saved; 400 lbs solid waste not generated; 47,000 lbs net greenhouse gases prevented; 36,000,000 BTUs energy not consumed. Calculations provided by Environmental Paper Network. FSC® is not responsible for any calculations on saving resources by choosing this paper.

This brochure is printed in the U.S.A. on 10% recycled paper. ©2022 Subaru of America, Inc. 23.OBKSRB.525 (DSGN-P293, 175K, 7/22, KSL)

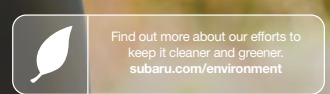

Love.® It's what makes Subaru, Subaru.

